

- NOTES:**
1. RAISED PAVEMENT MARKERS TO BE USED AS REQUIRED AND MUST BE APPROVED BY COUNTY ENGINEER/INSPECTOR.
  2. TACK COAT (CRS2H, SS1 OR AC30) TO BE USED AS REQUIRED.
  3. PRIME COAT (RC70) TO BE USED AS REQUIRED.

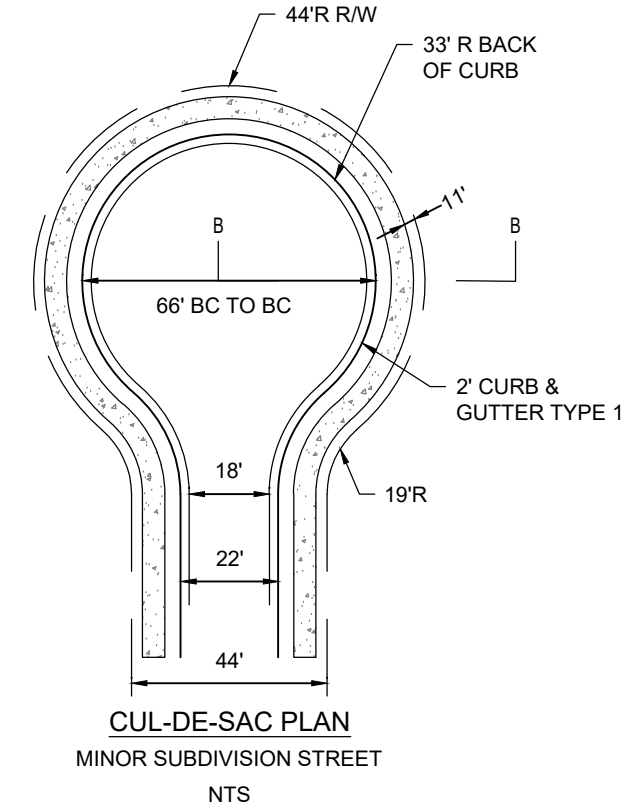
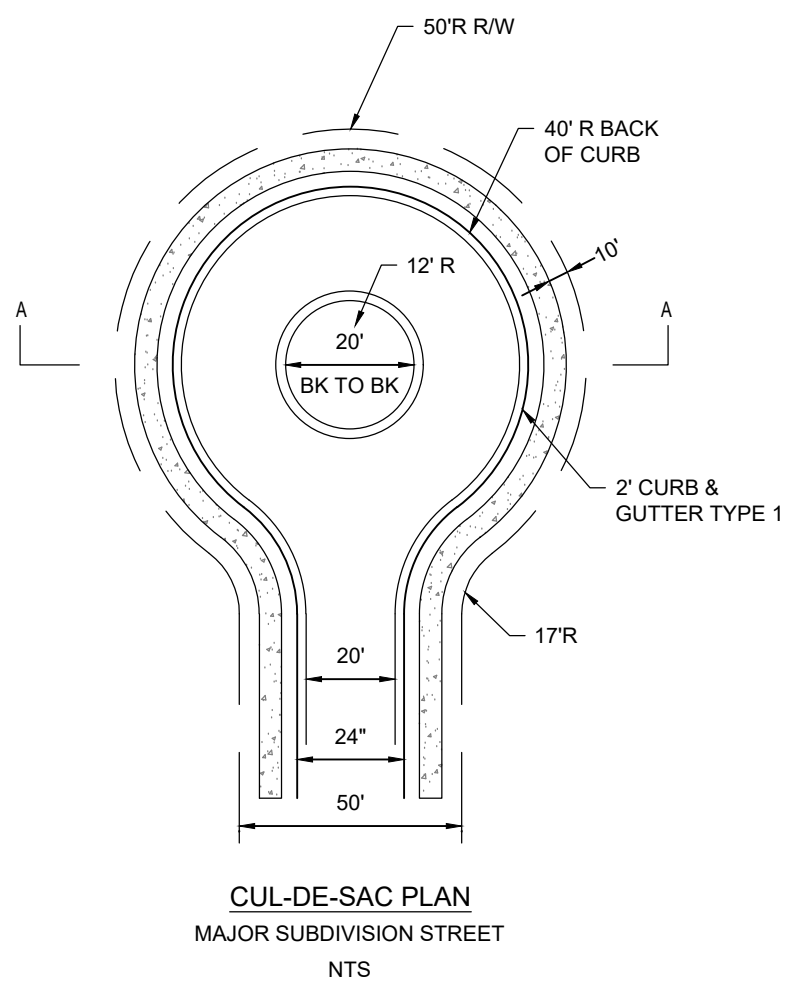

TABLE 303-1 MAJOR SUB.DIV.STREETS & ENTRANCE SCHEDULE	
PAVEMENT MATERIAL SCHEDULE	
(A)	ASPHALT, CONCRETE 9.5 mm SUPERPAVE, 165 LB/YD <sup>2</sup> (1-1/2")
(B)	ASPHALT, CONCRETE 19 mm SUPERPAVE, 220 LB/YD <sup>2</sup> (2")
(C)	GRADED AGGREGATE BASE (CRUSHER RUN) 8"

TABLE 303-2 MINOR SUB.DIV.STREET & SIDE ROADS	
PAVEMENT MATERIAL SCHEDULE	
(A)	ASPHALT, CONCRETE 9.5 mm SUPERPAVE, 165 LB/YD <sup>2</sup> (1-1/2")
(B)	ASPHALT, CONCRETE 19 mm SUPERPAVE, 220 LB/YD <sup>2</sup> (2")
(C)	GRADED AGGREGATE BASE (CRUSHER RUN) 8"

TABLE 303-3 SLOPE TABLE			
CUT SLOPE		FILL SLOPE	
0'-5"	5' OR MORE	0'-5'	5' OR MORE
4:1	2:1	4:1	2:1

**100% SUBMITTAL**

95% SUBMITTAL

<b>FULTON COUNTY STANDARD DETAIL 303</b>  <b>TYPICAL SECTIONS</b> <b>CUL DE SAC</b>		<table border="1" style="width: 100%; border-collapse: collapse;"> <thead> <tr> <th>DATE</th> <th>REVISIONS</th> <th>DATE</th> <th>REVISIONS</th> </tr> </thead> <tbody> <tr> <td>M/Y</td> <td>XXX</td> <td>M/Y</td> <td>XXX</td> </tr> <tr> <td> </td> <td> </td> <td> </td> <td> </td> </tr> <tr> <td> </td> <td> </td> <td> </td> <td> </td> </tr> <tr> <td> </td> <td> </td> <td> </td> <td> </td> </tr> </tbody> </table>	DATE	REVISIONS	DATE	REVISIONS	M/Y	XXX	M/Y	XXX													DGS/DRN/CHKD: <u>   XXX   </u> APPROVED: <u>   XXX   </u> DATE: <u>   XX-X-XX   </u>		FULTON COUNTY PUBLIC WORKS 141 PRYOR ST. ATLANTA, GA. 30303 404-612-7400 FAX: 404-224-0498	DRAWING NO.  <b>303</b>
	DATE	REVISIONS	DATE	REVISIONS																						
M/Y	XXX	M/Y	XXX																							